

Sunfix plus®

The intelligent pitched roof mounting system

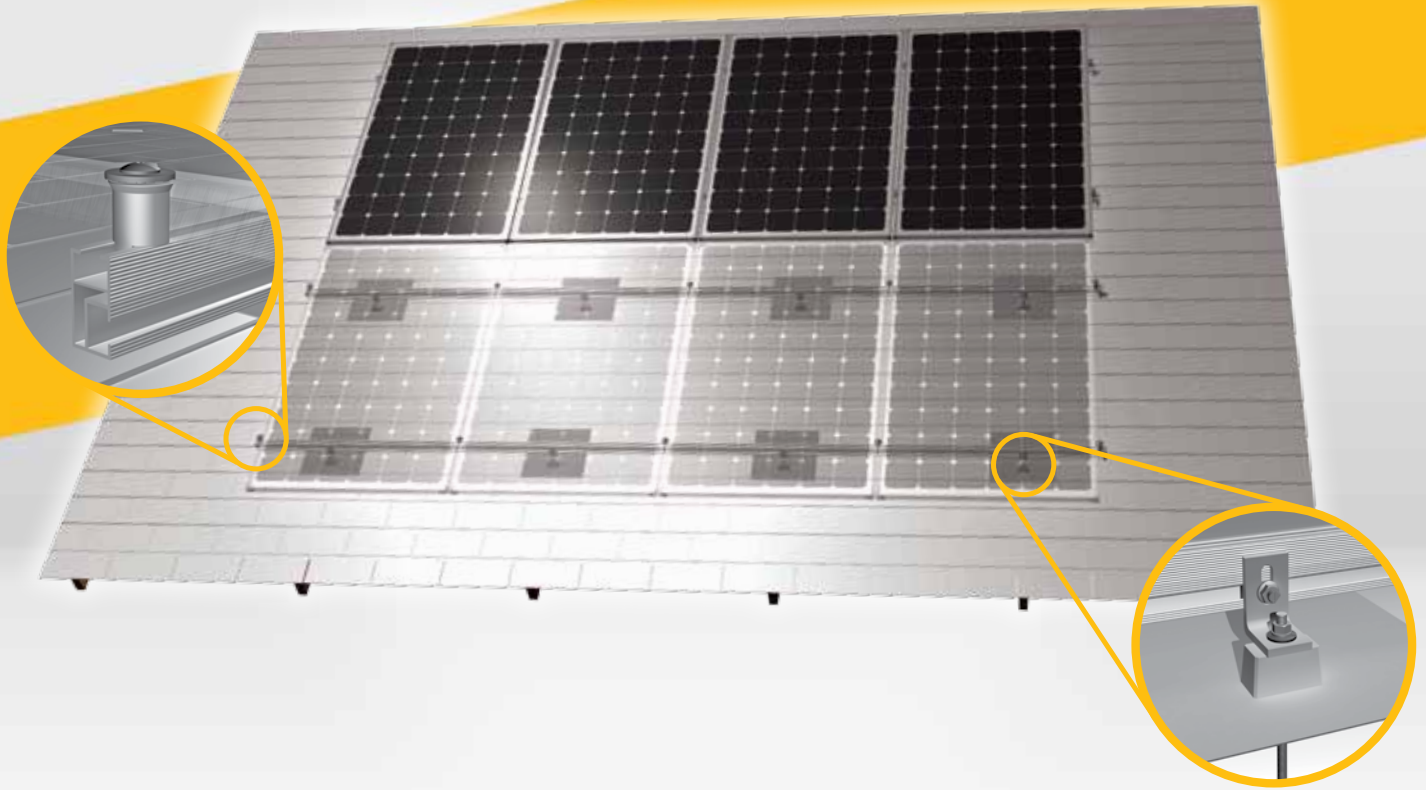

The SolarWorld Sunfix plus® pitched roof mounting system is optimized for simple and efficient installation of SolarWorld Sunmodule™ panels. The Sunfix plus system offers many value-added improvements ensuring trouble free assembly.

- For flush mounting to pitched roofs
- Multiple roofing applications: composition shingle, standing metal seam, flat or curved concrete tile
- Supports high wind and snow loads
- Pre-assembled hardware designed for fast and easy installation
- Preset rail lengths simplify planning and reduce material cut-off
- P.E. certified CA. 2010 Building Code, ASCE 7-05 & 2009 International Building Code
- Top clamps available for other modules (40 mm - 50 mm frames)



MADE IN USA

www.solarworld.com



We turn sunlight into power.

TECHNICAL SPECIFICATIONS

Load rating	170 mph wind at 50 psf snow
Array area weight	0.42 lb/ft ²
Roof pitch	9° to 45°
Orientation	Portrait or landscape - flush to roof
Rail lengths	1, 2, 3, and 4 module widths
Top clamps	M8 stainless steel - Torx T40 drive
Top clamp installation	Channel nut design - 15 ft-lbs torque
Top clamp colors	Silver or black
Splice bar	Aluminum, fastener free installation
Extruded material	6005-T5 aluminum alloy
Aluminum finish	Clear or black anodized

FEATURES

- Pre-assembled module 'top-clamp' hardware
- Top clamp with retainer stays in place during installation
- No field drilling of rails is required
- Splice bar with insertion stop - allows thermal expansion
- L-foot needed on only one side near rail splice bar
- Wire management stainless steel cable S-clips
- Anodized aluminum components resists oxidation affects
- Compatible with approved WEEB grounding devices
- All components and custom rail lengths in bulk quantities
- Improved attachment spans and load ratings
- 10-year limited warranty

COMPONENTS

- 1 Sunfix plus rail (2 required) - 2 modules = 82", 3 modules = 122", 4 modules = 162"
- 2 Top-clamp for 31 mm frame - M8 bolt
- 3 Channel nut with bolt positioning retainer
- 4 End clamp aluminum spacer - 31 mm
- 5 Rail splice bar; joins rails together
- 6 L-foot with dual adjustment slots & mating serrations
- 7 T-bolt M8 x 20 stainless steel with serrated flange nut
- 8 Rail splice ground jumper WEEB 8.0 pre-assembled with bolts
- 9 Rail-equipment ground WEEB-lug 8.0 with bolt assembly
- 10 Roof attachment/flashing - Quick Mount PV® (silver or black)

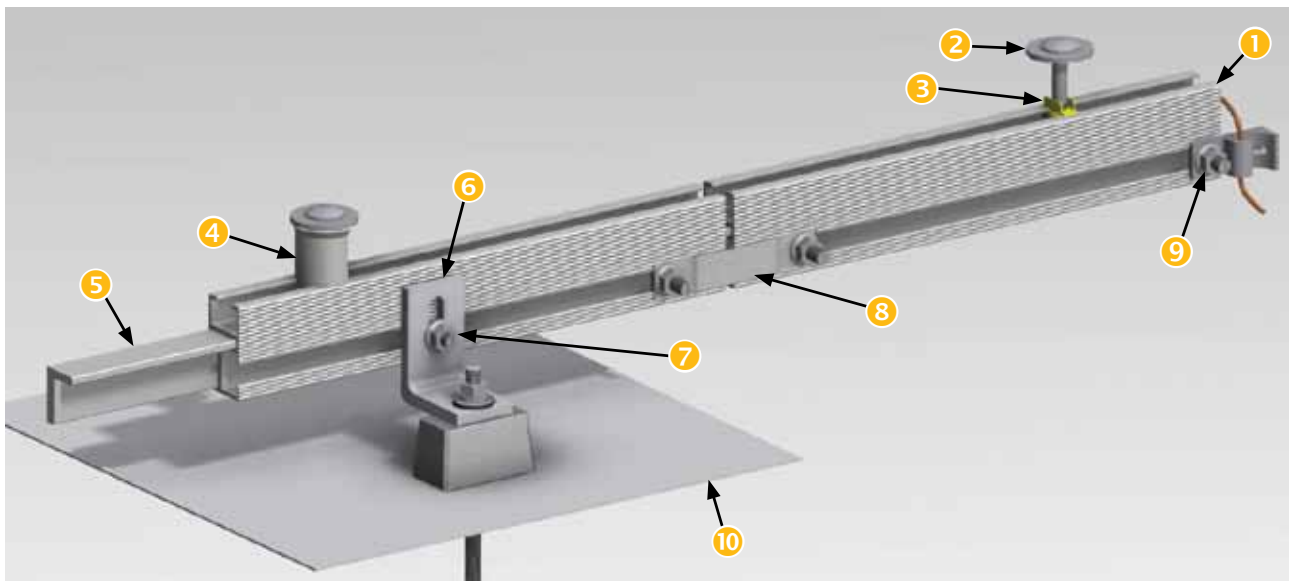

ROOF MOUNTING OPTIONS



Composition



Flat tile



S-Tile

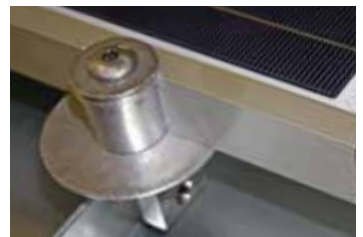

Standing seam clamp