



250 / 6 PL US AC PHOTOVOLTAIC MODULE

Our ARRA compliant, ETL listed AC modules are the next generation of solar technology providing up to 25% more energy compared to traditional DC PV modules. Combine our high-efficient MAGE POWERTEC PLUS modules with a revolutionary micro-inverter to convert DC voltage into grid connected AC, creating power anywhere, anytime.

25% More Energy For Less Costs

- › Producing up to 25% more energy than alternative systems
- › Industry leading 30 year power guarantee on module encompassing attached micro-inverter
- › Reduces upfront costs by eliminating costly inverters, installation material and complex system designs

Easier, Faster, Safer

- › Plug and Play - simplifies installation process
- › Safer installation and ownership by eliminating the danger of high voltage DC

Module Level Energy Monitoring

- › Web-based management system for 24/7 monitoring
- › Monitor real-time operating performance of every AC module

Flexible Design

- › Ideal for homes, small businesses, parking canopies, etc.
- › Suitable for any rooftop - even complex or shaded
- › Increase your system size when you want it, when you need it – module by module



Number of Cells: 60
Solar Cell Type: polycrystalline
Power class: 250 Wp

30	YEAR 80% POWER GUARANTEE	12	YEAR 90% POWER GUARANTEE	10	YEAR PRODUCT WARRANTY	+5	WATTS POSITIVE TOLERANCES
----	--------------------------	----	--------------------------	----	-----------------------	----	---------------------------

AC ELECTRICAL CHARACTERISTICS

AC Output Rating	208 V	240 V
AC Output Voltage (Min/Nom/Max)	183 V / 208 V / 229 V	211 V / 240 V / 264 V
Oper Freq Hz (Min/Nom/Max)	59.3 / 60.0 / 60.5	
Output Power Factor	0.99 min	
AC Max Cont Output Current	1.14 A	0.992 A
AC Max Cont Output Power	238W	
Max Units Per Branch Circuit	24(3 Pole) or 14(2 Pole)	16
Max Overcurrent Protection	20 A	
Total Harmonic Distortion	< 5%	

DC ELECTRICAL CHARACTERISTICS*

Maximum Power Rating	P _{mp} (W)	250
Tolerance of P _{mp}	(W)	-0/+5

* STC @ 25° C, 1000 W/m², AM 1.5

TECHNICAL FACTS

Number of Cells (Matrix)	60 (6 x 10)
Solar Cell Type	polycrystalline
Solar Cell Size (mm)	156 x 156
Solar Cell Size (in)	6 x 6
Dimensions (LxWxH mm)	1655 x 989 x 39
Dimensions (LxWxH in)	65.15 x 38.94 x 1.54
Weight (kg)	21.3
Weight (lbs)	47.0
Module Efficiency (%)	15.3

DC THERMAL CHARACTERISTICS

NOCT	(°C)	+ 46 ±2
Temperature Coefficient	I _{sc} (%/°C)	+ 0.05
Temperature Coefficient	V _{oc} (%/°C)	- 0.32
Temperature Coefficient	P _{mp} (%/°C)	- 0.43

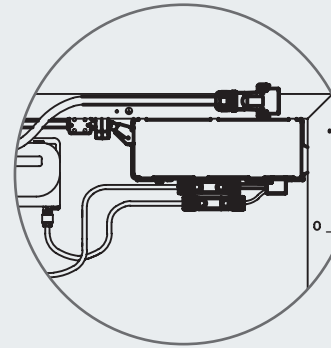
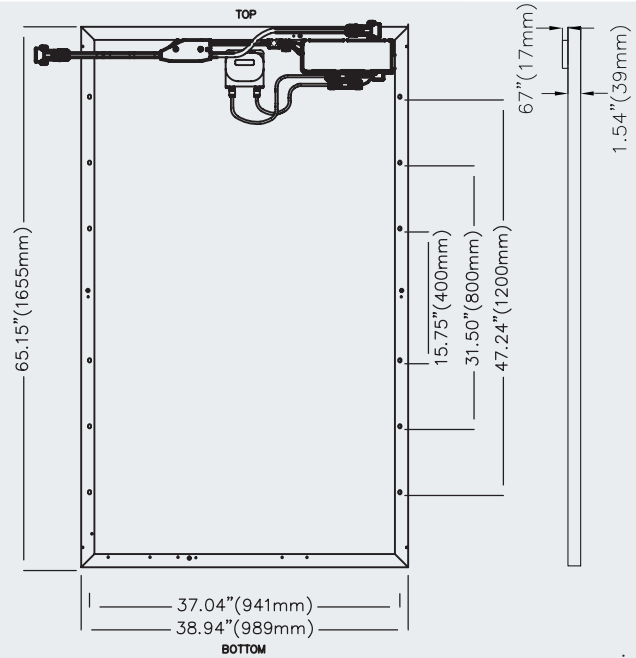

MAGE POWERTEC PLUS AC module with attached micro-inverter



UP TO **25%** more energy than traditional systems



Easy to install around shaded areas & on complex rooftops



Unmatched 30 Yr. Performance Guarantee



EASY plug & play



24/7 monitoring



MAGE SOLAR USA

720 Industrial Boulevard · Dublin, Georgia 31021 USA

Toll-free (877) 311-6243 · Main Office (478) 609-6640 · Fax (478) 275-7685

info@pagesolar.com · www.pagesolar.com



Intertek
UL1703
UL1741



CEC

FSEC