

MAGE 250W / 6PL SOLAR PANEL (TYPICAL 4)

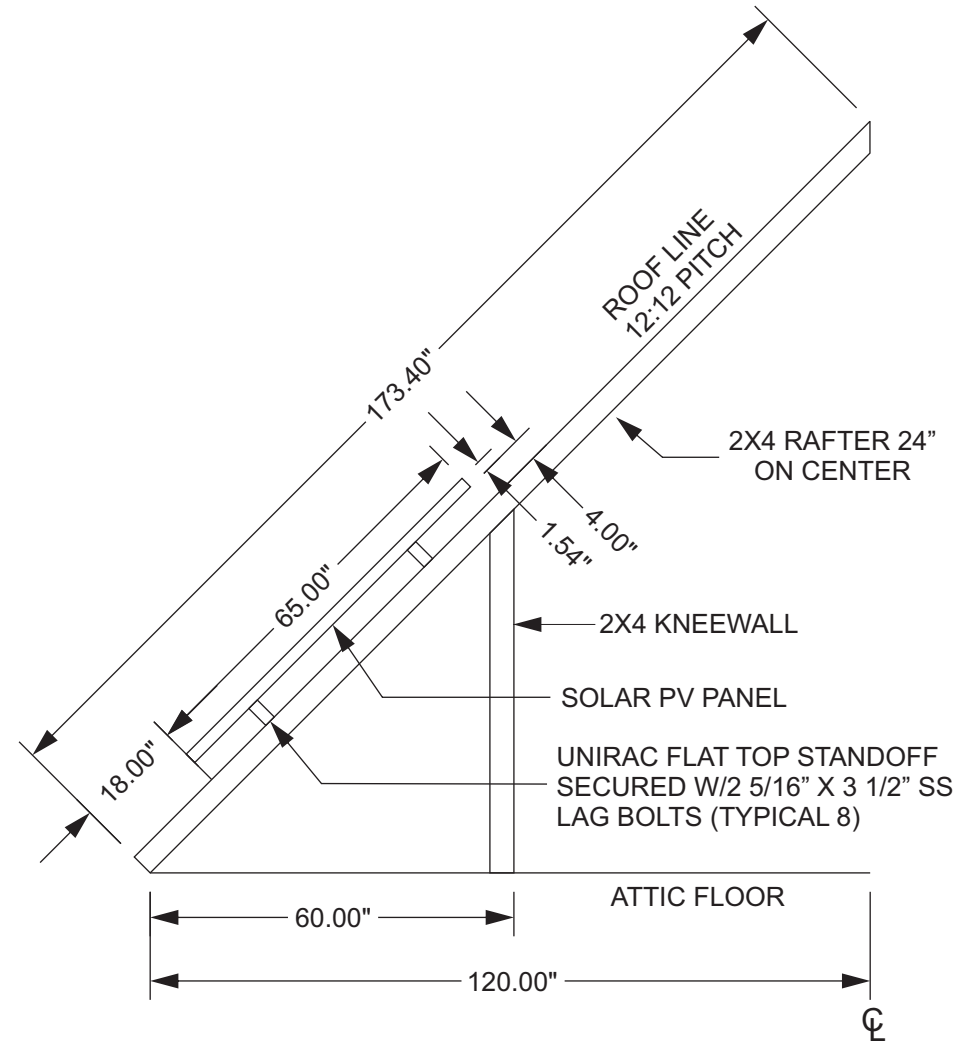
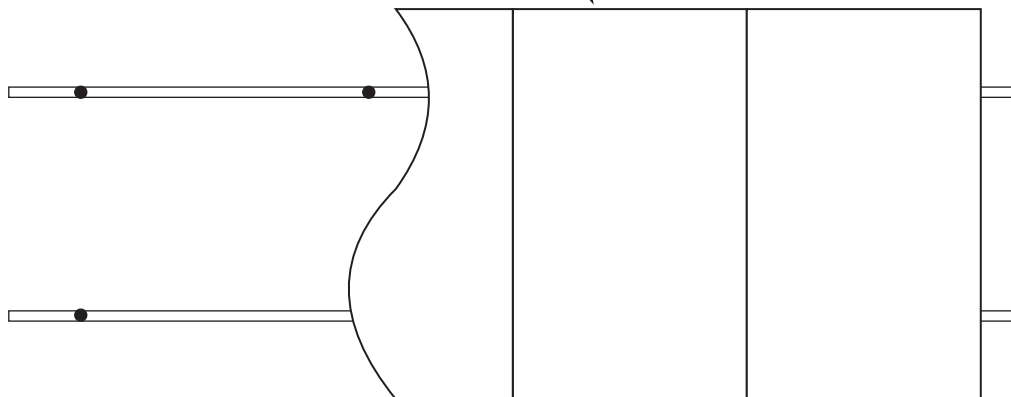

NOTES:
RACKING WEIGHT = 0.77PSF
SYSTEM WEIGHT = 3.22PSF
ALL DIMENSIONS IN INCHES

PROJECT SITE:
9227 GOODWIN
DETROIT, MI 48211

GREATER WOODWARD CDC
8850 WOODWARD AVE.
DETROIT, MI 48214

DRAWN BY:	KM
DRAWING DATE:	09/09/13
SCALE:	1/32" = 1"